

AURORA

Shredder User Manual



1-800-327-8508
USA Only

1-310-793-5650
International

Email: info@auroracorp.com

For more information, please visit us at:
www.auroracorp.com

AU405MA

Model No.

Please read these operating instructions before using the unit.

WARNING: SAFETY INSTRUCTIONS, READ BEFORE USING!



Read instructions before use.



Do not spray or keep any aerosol products in or around the shredder.



Avoid touching the document feed opening with hands.



Keep loose clothing or jewelry away from the paper entry slot.



Product is not intended for use by children (product is not a toy).



Avoid getting hair near the paper entry slot.



Do not insert foreign objects into the paper entry slot.



Keep away from moving parts.



Sharp blade edges!
Do not touch!

DO NOT SHREDS:



adhesive labels



unopened mail / envelopes



stapled papers



stapled papers



>1 1/4" (6mm) heavy duty staples



bound documents



folded sheets



jumbo clips



binder clips



laminated sheets / magazines



no staples in center



avoid placing staple side here



avoid placing staple side here

Note: Do not open lid once shred cycle has started

CONTINUED NEXT PAGE

WARNING: SAFETY INSTRUCTIONS, READ BEFORE USING!

- **Always turn the shredder off and unplug the power cord from the AC outlet when not in use, before cleaning, moving, or emptying the waste basket.**
- **RISK OF FIRE. Never use any petroleum based or flammable oils or lubricants** in or around the machine as some oils can combust causing serious injury.
- NEVER dispose of flammable chemicals or materials that have come into contact with flammable chemicals (for example, nail polish, acetone and gasoline) in the shredder basket.
- **Never shred metal credit cards, large paper clips, window or insulated envelopes, continuous forms, newsprint, bound pages (for example: notepads, checkbooks, magazines, etc...), transparencies, laminated documents, cardboard, any items with adhesives, hard materials or plastic (except plastic Credit Cards and CDs).**
- **Do not hold CD/DVD with finger through the center ring while feeding into the shredder. Serious injury may occur.**
- A socket-outlet should be near the equipment and be easily accessible.
- Never let the wastebasket become full. This will lead to shredded material being pulled back up into the shredder and cause jams.
- Never place the shredder near water or any heat source.
- Do not use the shredder if the power cord is damaged in any way.
- Do not attempt to service this product yourself as doing so may expose you to sharp cutting blades and/or electricity and will void the manufacturer's warranty.
- Never try to clean or clear the shredder blade.
- Never shred beyond the specified sheet capacity. This may result in extensive damage to the machine.

Paper Shredder Operating Instructions

- Warning
- Installation
- Operation
- Maintenance
- Troubleshooting

	Auto Feed Tray:	Manual Feed Slot:
Sheet Capacity	400 Sheets of 20 lb. letter size bond paper	10 Sheets of 20 lb. bond paper*
Paper Shred Size	5/64 in. x 15/32 in. pieces (2.0 mm x 12 mm pieces)	5/64 in. x 15/32 in. pieces (2.0 mm x 12 mm pieces)
Paper Tray Size:	Letter size- 8.5" x 11"	N/A
Paper Entry Width	9.45 in / 240 mm	9.45 in / 240 mm
Duty Cycle	240 min. on / 45 min. off	30 min. on / 45 min. off
Voltage	120-V~60Hz / 4.0 A	120-V~60Hz / 4.0 A

* Manual Feed:

- Shreds credit cards, CDs/DVDs, small paper clips, staples
- One folded sheet of paper equates to 2 sheets of paper
- Heavier paper, humidity or electrical voltage other than the rated voltage may reduce shredding capacity

INSTALLATION

1. Make sure basket door is shut and securely closed. The safety power cut off will not operate if door is open. Shredders with pull-out wastebaskets will also cut power upon bin removal. The supplied wastebasket activates a safety switch, which allows the shredder to be operable. (FIGURE 1).
2. The socket-outlet should be near the equipment and easily accessed.
3. Connect the power cord to any standard 120-V AC outlet.

⚠ Caution:

Micro-cut shredders have very sharp exposed blades on the underside.



OPERATION



■ Main Power Switch (at back of machine)

The Main Power Switch must be "ON" to operate. In an emergency, stop the shredder immediately and turn switch to "OFF" mode. This completely disconnects all power to the machine.

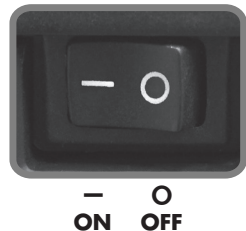

■ Control Panel:

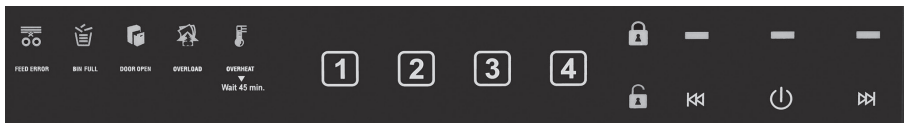

• Auto-On (blue):



This setting automatically starts the shredder by loading paper into the paper tray or inserting paper into the manual-feed slot. When the paper has passed through, the shredder automatically stops.

CONTINUED NEXT PAGE

OPERATION



- **Off :**

This setting turns off all features of the shredder. For safety reasons, we recommend that you leave shredder in the OFF position when it is unattended or not in use.



REV

- **Reverse:**

In the unlikely event of a paper jam, use the reverse setting to help clear the cutters of paper that did not pass through. **IMPORTANT:** Never attempt to clear a jam using the reverse function until you have emptied the wastebasket.



FWD

- **Forward:**

The forward setting can also be used to help clear the cutters in the event of a paper jam. This allows you to manually activate the shredder into cutting mode.

■ LED Status Indicators:



OVERHEAT

- **Overheat:**

Red LED light indicates the shredder has shredded continuously beyond the maximum running time, has overheated, and will automatically shut off. If this happens, switch the shredder to Off for 45 minutes or longer before resuming normal operation.



OVERLOAD

- **Overload:**

Red LED light indicates when too much paper is inserted. Use the "Reverse" mode to back up and reduce number of sheets.



DOOR OPEN

- **Door Open:**

Red LED light indicates the shredder basket or top lid is not closed properly. Shredders with pullout wastebaskets feature a safety power cut off upon bin removal. Make sure the pull-out wastebasket is properly set back into place and the blue "Power On" indicator is lit.



BIN FULL

- **Bin Full:**

When basket is full, RED light will indicate it needs to be emptied. While lit, the shredder will not operate until the wastebasket is cleared.



FEED ERROR

- **Feed Error:**

RED light indicates paper in the paper tray cannot be grabbed by the feeders, Open lid to make sure papers are unfolded and positioned properly.

■ Top Lid Security Lock:



- **To lock the top lid:** Enter any 4-digit code during shredding



- **To open the top lid:** Enter the same 4-digit code to unlock

CONTINUED NEXT PAGE

OPERATION

Top lid unlocks automatically when:

1. Shredding is complete.
2. Shredder is inactive for 30 minutes when documents remain in the paper tray or shedding error occurs.

■ Features:

● **Auto-Reverse Technology:**

When shredder detects over-capacity shredding, the motor will immediately stop and reject paper before actual shredding begins.

● **Energy Saving Auto Power-Sleep:**

This setting turns off all features of the shredder. For safety reasons, we recommend that you leave shredder in the OFF position whenever it is unattended or not in use.

● **Top Lid Security Lock:**

To lock the top lid: Enter any 4-digit code during shredding

To open the top lid: Enter the same 4-digit code to unlock

Top lid unlocks automatically when:

1. Shredding is complete.
2. Shredder is inactive for 30 minutes when documents remain in the paper tray or shedding error occurs.

● **Features a CD/DVD and Credit Card destroyer:**

1. Lift up the top lid.
2. Insert CDs/DVDs or credit cards into the CD/DVD/Credit Card slot. Only shred credit cards by feeding them horizontally into the middle of the entry, releasing when shredding begins. Never feed more than one credit card at a time.
3. Close the top lid.
4. Shredder will stop when the entire disc or credit card has been destroyed.

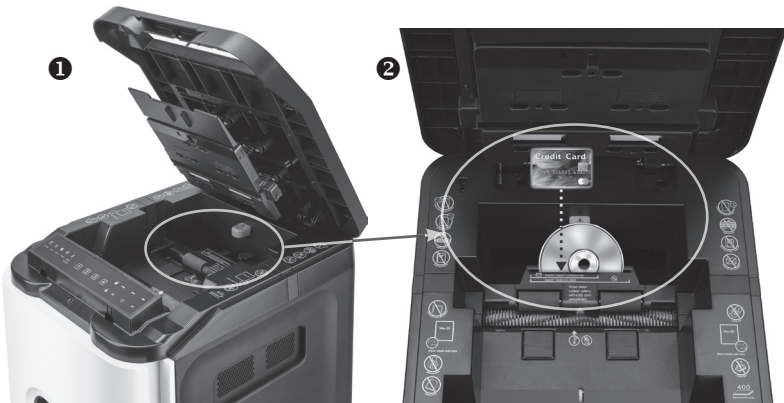

CONTINUED NEXT PAGE

OPERATION

■ Auto-Feed Shredding Operation:

• Auto-Feed Shredding Capacity:

Shreds:

- Maximum 400 sheets of letter size (8-1/2" x 11") 20 lb bond paper per load
- Up to 20 sheets stapled paper stacks
- Up to 20 sheet clipped paper stacks

• Power on shredder

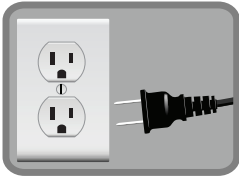

- 1 Plug into ground standard US household power outlet (120V).



- 2 Put main power switch in ON (-) position.

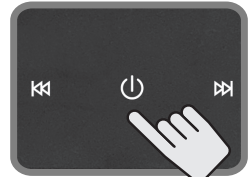

- 3 Turn power on.

• Open lid and load paper*



* Paper should be flat and aligned with paper tray.

• Close lid:

The shredder automatically starts when you close the lid.



CONTINUED NEXT PAGE

OPERATION

■ Manual-Feed Shredding Operation:

• Power on shredder

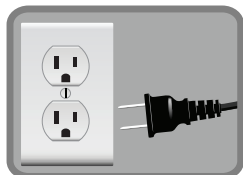

- 1 Plug into ground standard US household power outlet (120-V).

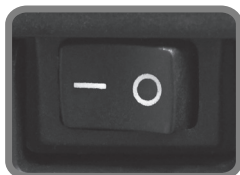

- 2 Put main power switch in ON (-) position.



- 3 Turn power on.



- 4 Make sure you do not exceed sheet count per pass (10 sheets max). **Insert paper as straight as possible into feed slot and release.**



- 5 Only shred credit card by feeding it vertically into the middle of the entry, releasing when shredding begins. Never feed more than one credit card at a time.

■ NOTE:

- Always turn off and unplug the shredder when not in use.
- This shredder will shred staples and small paper clips. It is recommended that you remove paper clips whenever possible to extend the lifespan of your shredder.
- Only shred credit cards by feeding them vertically into the middle of the entry, releasing when shredding begins. Never feed more than one credit card at a time.
- Overfeeding the shredder: Shredding beyond the specified sheet capacity can result in extensive damage to the shredder. Overfeeding will strain the machine and quickly wear and break the cutting blades and internal components.
- Overheating with extended use: In the event that the shredder has shredded continuously beyond the maximum running time and overheating, the unit will automatically shut off. If this happens, switch the shredder off for 45 minutes or longer before resuming normal operation.

CONTINUED NEXT PAGE

MAINTENANCE

■ **Warning: Failure to properly maintain your shredder will void the warranty.**

■ **To maintain with shredder oil (shredder oil not included):** Oil the shredder blades every month with basic vegetable, cooking oil or shredder oil. Follow oiling procedure below. It helps to keep the shredder blades operating well over many years of use.

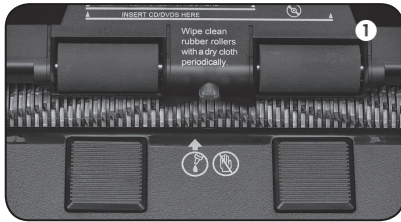

Oiling procedure:

1. Open lid.
2. Carefully apply shredder oil across feed slot.

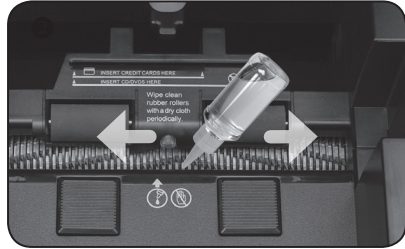

3. Close lid and turn shredder in reverse mode for 3-5 seconds.

■ **To maintain with a shredder sheet (shredder sheet not included):**

- Simply insert shredder sheet into the manual-feed slot the same way you would a piece of paper.
- Turn shredder in reverse mode for 3-5 seconds.



Note: Shredder oil and lubricant sheet are not included.



⚠ Caution:

- Do not spray or keep any aerosol products in or around shredder.
- DO NOT USE CANNED AIR ON SHREDDER.

■ CLEANING:

- ALWAYS UNPLUG THE SHREDDER BEFORE CLEANING!
- Only clean the shredder by carefully wiping the unit with a dry soft cloth or towel.
- Do not clean or immerse shredder in water. Having the unit wet may result in damage or malfunction to the electrical components. If the shredder happens to get wet, be sure to completely dry the unit immediately with a cloth or towel.
- Never use anything flammable to clean the shredder. This may result in serious injury or damage to the product.

CONTINUED NEXT PAGE

TROUBLESHOOTING

If there is a problem with your shredder, check below for the symptoms and steps to resolve. If you continue to have problems, contact customer support at our Service Center.

DO NOT ATTEMPT TO REPAIR BY OPENING THE SHREDDER HEAD. This will completely void the product warranty.

No-power to the shredder

1) Check power outlet

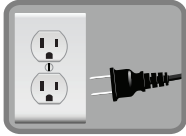

2) Check main power switch located at back of machine

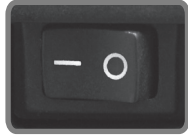

1) Make sure power cord is plugged into a functioning 120-V standard household power outlet.

2) Check if the blue Power On icon is lit.

3) Check that the lid and waste bin are properly closed.

Shredder does not feed or shred paper

Overheat



Cool down



If Overheat light is lit in red, turn shredder off and let it cool down for 45 minutes. Turn shredder on, check Overheat light again, and restart shredding only when light is not lit.

Auto-Feed mode:

If Feed Error icon is lit



FEED ERROR

RED light indicates paper in paper tray cannot be grabbed into shredding slot. Open lid to make sure papers are unfolded and positioned properly.

Shredder is jammed or runs continuously



- Open lid, remove the remaining stack of paper and carefully pull the jammed paper out of the cutters.
- Remove folded papers, staples and clips.
- Remove any materials with adhesive labels.
- Make sure papers are positioned properly. Staples must be placed in either lower left or lower right of paper tray.

CONTINUED NEXT PAGE

TROUBLESHOOTING

Manual-Feed mode:

Shredder is jammed and runs in "Reverse" mode only /



Overload icon is lit in red

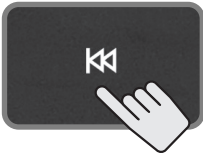

1 Reverse for 5 sec

2 Power Off then pull paper side to side



3 Reduce sheets

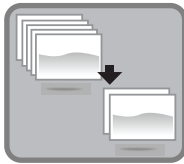

⚠ Warning: DO NOT USE ANY SPRAY CANS OR AEROSOLS.

- 1) Press the reverse button () for 5 sec.
- 2) Turn off shredder then pull paper side to side to remove jammed paper (as much as possible).
- 3) Reduce the number of sheets being fed (count pages to be sure not to exceed the maximum sheet count).

With stubborn situations where the reverse function does not help, follow the steps below:

1 Turn off shredder



3 Turn on shredder



4 Press "Forward"

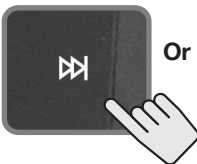

Or

2 Apply shredder oil and wait for 30min.

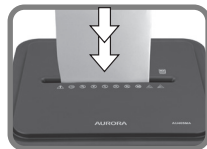

Use thick paper to push jam through

- 1) Turn off shredder.
- 2) Apply shredder oil to the feed slot (shredder oil not included). Let oil soak in to paper and machine for 30 minutes.
- 3) Set the Power button to Auto/On.
- 4) Press forward button () or use thick paper stock/ greeting card to manually activate the shredder into cutting mode or push the jam through.
- 5) Reduce the number of sheets being fed (count pages to be sure not to exceed the maximum sheet count). Refeed the paper.

Shredder does not feed or shred credit card or small piece of paper



Feed in the center

- Position credit card or small piece of paper over the credit card section of the Feeder (center position).
- Try again.

SERVICE CENTER

If you have any questions in regards to the operation of this shredder or in need of a spare part, please contact our service center at:

Aurora Corp. of America

Telephone: **1-800-327-8508 (U.S.A. only) or 1-310-793-5650 (International)**

Business hours: Monday to Friday 8:00 am - 5:00 pm PST (Pacific Standard Time)

Email: info@auroracorp.com

Or for more information, please visit our website at <http://www.auroracorp.com>

LIMITED PRODUCT WARRANTY

Aurora warrants the cutting cylinders of the machine against defects of workmanship and material for a period of **5 years** from the original purchase date to the original consumer. Aurora warrants all other parts of the machine against defects of workmanship and material for a period of **1 year** from the original purchase date to the original consumer.

Should there be a defect or malfunction of this product, Aurora will repair or replace the product free of charge. Customer is responsible for all shipping charges to return the defective product to Aurora. **A copy of the proof of purchase showing original purchase date is required.** This warranty is void if the product has been subject to damage, unreasonable use, improper service, or other causes not arising from defects in original material or workmanship. This warranty is void if factory seal is broken or removed from the product. This warranty does not include adjustments, parts or repairs required by circumstances beyond the control of Aurora.

There are no expressed warranties other than those stated herein.

Any expressed or implied warranties, including but not limited to merchantability and fitness for a particular purpose are limited to the above warranty period. Aurora shall not be liable for any incidental or consequential cost, expenses or damages resulting from any failure defect or malfunction of this product.

Some states do not allow the exclusion of limitations of implied warranties or consequential damages, therefore, the above limitations may not apply to you.

This warranty grants you specific legal rights, and you may also have other rights that vary from state to state.

Before returning any product, please call our Service Center for specific return instructions.

Aurora Corp. of America: 1-800-327-8508 USA ONLY

1-310-793-5650 INTERNATIONAL • info@auroracorp.com

AURORA

1-800-327-8508
USA Only

•

1-310-793-5650
International

•

Email: info@auroracorp.com

•

For more information, please visit us at:
www.auroracorp.com